

# A definitive guide to earthing and bonding in hazardous areas

by LC Towle BSc CEng MIMechE MIEE MInstMC  
Technology Director  
The MTL Instruments Group plc

## 1 Introduction

This document details what has proved to be acceptable practice for earthing and bonding of electrical apparatus used in hazardous areas. The subject is not complex, but partially because it is relevant to more than one area of electrical expertise a systematic approach to the subject is desirable. There are numerous codes of practice which specify how earthing and bonding should be carried out, but the fundamental requirements are independent of the geographic location of the installation and hence there should be no significant difference in requirements. This document predominantly describes what is acceptable practice in the United Kingdom and Europe. If a national code of practice exists and differs fundamentally from this document then it should be questioned. It may be considered expedient to comply with such a code but it is important to be assured that doing so results in a safe installation.

Some parts of this note state what are well-known basic principles to practising electrical and instrument engineers. They are restated primarily for the sake of completeness, and ease of reference.

## 2 Definitions

One of the major causes of difficulty is that the terms bonding and earthing are used interchangeably. In this document the terms are defined as follows.

*Earthing* is the provision of a specific return path for fault currents so as to operate protective devices in a very short time.

*Bonding* is the interconnection of two adjacent pieces of conducting material so as to prevent a potential difference between them which would be a hazard to people or be capable of causing an ignition.

Occasionally a system is referenced to the ground on which it stands by using mats of copper or rods driven into the ground. For the purpose of differentiating this process from that of earthing and bonding in this document, this process will be referred to as grounding.

## 3 The reasons for earthing and bonding

The basic reasons for earthing and bonding are quite simply:

a) To provide a dedicated reliable low-impedance return path for fault currents so that the fault can be detected and the source of power removed as quickly as possible.

b) To prevent potential differences which would create a possible electrocution hazard to personnel or produce sparking capable of causing ignition.

c) To minimise the effect of lightning strikes either directly on the installation or adjacent to it.

d) To control or prevent the build-up of electrostatic discharges.

e) To minimise the effect of electrical interference and provide a signal reference for instrumentation systems.

f) To satisfy segregation and define fault-path requirements necessary to ensure the safety of explosion-proof apparatus.

It is desirable to remove fault currents as quickly as possible (less than a second) so as to prevent the dissipation at the point of fault from causing a fire or explosion. The majority of gases require a temperature in excess of 200°C to spontaneously ignite and a similar temperature can cause fires and will destroy conventional insulation.

It is interesting that the potential difference which is not acceptable from the electrocution requirement is not significantly different from that required to ignite gases. The sensitivity of the human body to electricity is quite complex since it is both frequency and time dependent. There are many excellent references on the subject, one of which is 'Touch Voltages in Electrical Installations' by BD Jenkins. A simplified analysis is represented by figure 1. This suggests that limiting the current between the body's extremities to 5mA can be achieved by restricting the available voltage to 25V rms over a separation of perhaps 2.5m.

Similarly the familiar ignition curves from the CENELEC apparatus standard, figure 2, suggest that a voltage in excess of 10V is necessary to create a spark capable of causing ignition. The requirements for spark prevention and electrocution are not therefore significantly different.

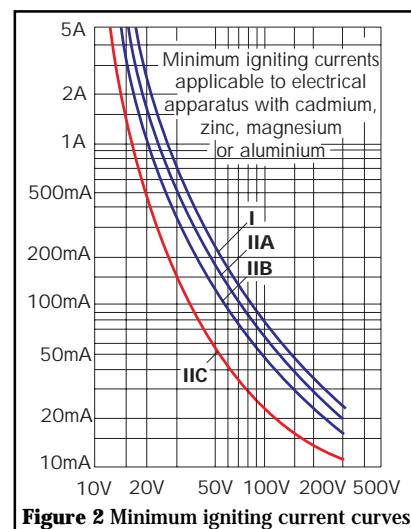


Figure 2 Minimum igniting current curves

The requirements of both bonding and earthing from an electrical viewpoint are not significantly more onerous on a hazardous plant than those of a conventional plant. The consequences of a failure may be more dangerous on a hazardous plant and consequently additional precautions to increase the reliability of the bonding and earthing are usually taken.

The following sections examine each of the fundamental requirements in more detail.

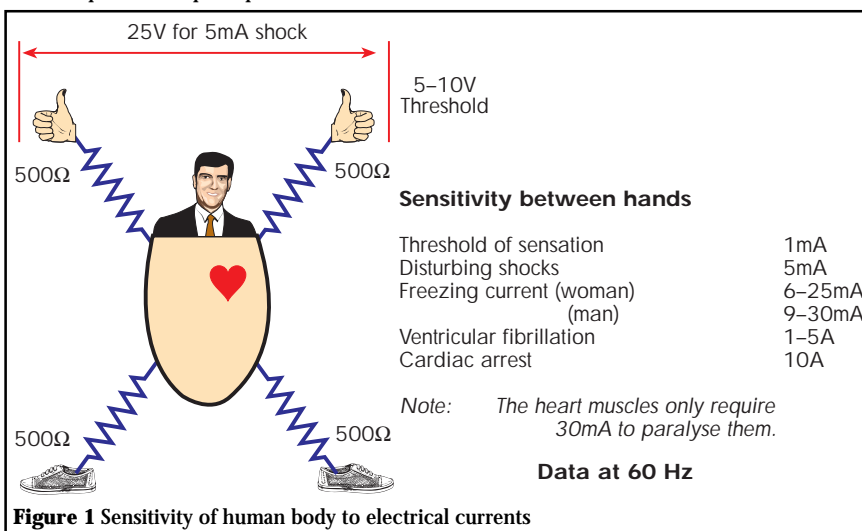


Figure 1 Sensitivity of human body to electrical currents

## 4 Earthing

The primary purpose of earthing is to provide a well-defined reliable return path for any fault current which may develop. The concept is best illustrated by considering the self-contained situation illustrated in figure 3 where the electricity is generated locally.

The fault current is returned to its source and not to ground. The return path has to provide a possible path wherever the fault develops and hence is usually connected to the metallic structure at any convenient point along its path.

Ideally a fault should cause sufficient current to flow to operate the protective devices in a relatively short time. A fault which has significant impedance would perhaps not allow enough current to flow so as to operate the protective fuses, and the resultant heat could create a hazard. In almost all installations providing power to hazardous areas it is not usual to rely on fuses for adequate electrical protection. A combination of earth leakage and out-of-balance current monitoring is almost always used.

During the time that the protective network takes to operate, the plant may be transiently at risk and consequently it is important to reduce this time as far as possible. This transient risk has always been accepted in Zone 1 and 2 locations but is possibly not acceptable in the continuously hazardous location of Zone 0. Where explosion-proof equipment must be used in Zone 0 then the difficult problem of minimising the transient fault current must be addressed.

## 5 Bonding

Bonding is the process which ensures that adjacent conducting materials are reliably connected together. An effective bond provides a path for structural currents and ensures that the interconnected objects are at the same potential.

Figure 4 illustrates how all the equipment is bonded to the structure, thus ensuring that no appreciable voltage difference which could be detrimental to personnel safety is created. The bond is effectively in parallel with the human and the fault current is divided between them. An effective bond will have a resistance of  $20\text{m}\Omega$  and therefore would need a fault current of  $1250\text{A}$  to generate the  $25\text{V}$  which is the maximum desirable to ensure personnel safety. Since there are invariably a number of parallel plant bonds, the probability of such a significant current flowing through a particular bond is very small.

When both bonding and earthing are complete, then fortunately they reinforce one another. The bond provides an alternative return path and the earthing conductor duplicates the function of the bond. The system becomes as illustrated in figure 5, creating an effective interconnected web of return path and bonding. This has the merit that safety is no longer dependent on a single conductor or connection. The resultant equipotential plane is not significantly different from that created

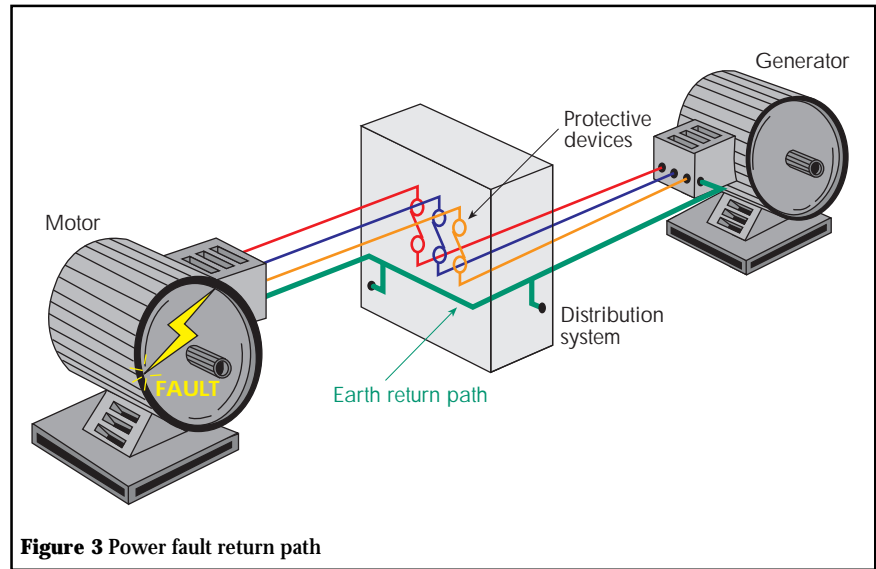


Figure 3 Power fault return path

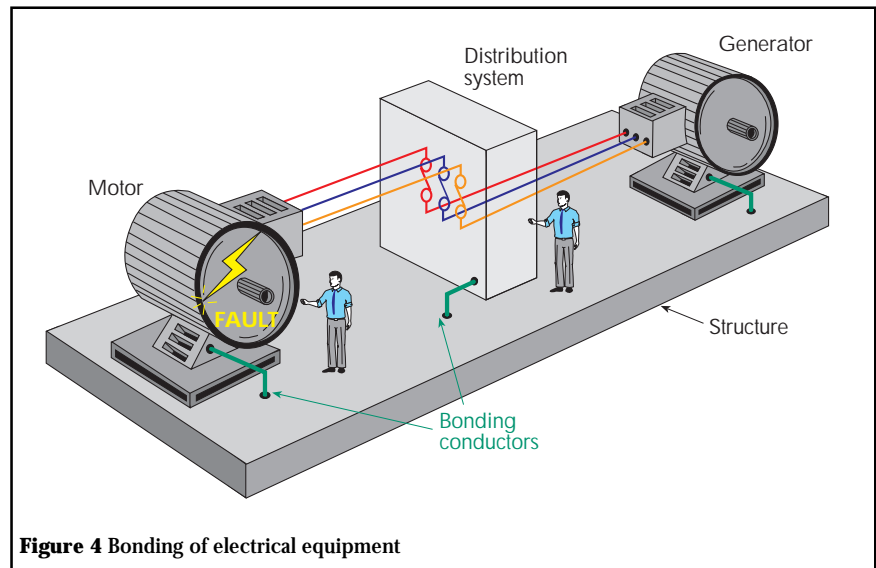


Figure 4 Bonding of electrical equipment

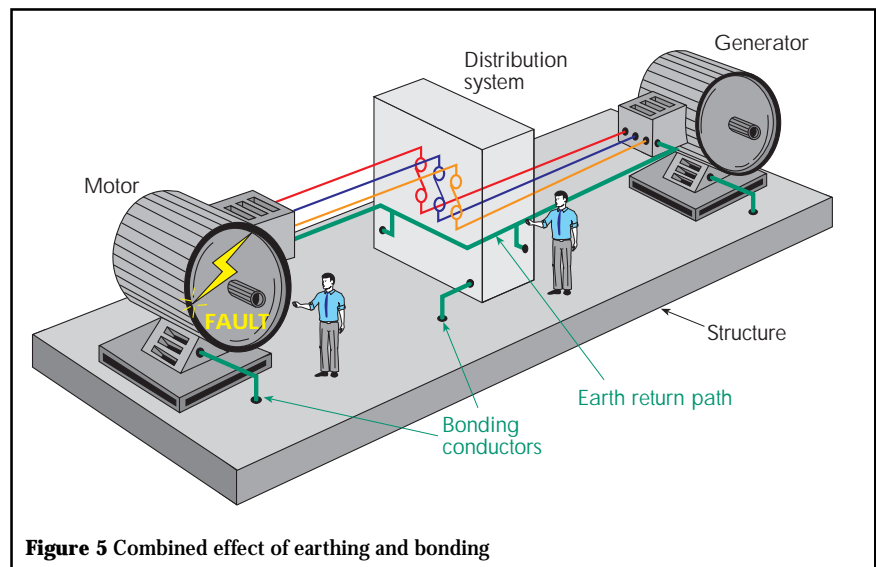


Figure 5 Combined effect of earthing and bonding

by the German practice of systematic interconnection of all system structures and deliberate earth mats. The merit of the German system is that adequate provision is made for easy connection to the equipotential plane which makes a clear statement of the desirable practice so much easier. If a plant is being constructed on a clear site then serious consideration to adopting the German techniques should be given.

A side-effect of having an effective equipotential plane is that its inductance is quite low which has a beneficial effect in reducing problems associated with high-frequency transmission and the fast rise-time transients of lightning but does not significantly affect mains frequency currents.

## 6 Grounding

The primary reasons for connecting electrical circuits and structures to the earth mats which attempt to make a connection to the surface of the planet are to provide a return path for the electrical supply to a plant, and to minimise the effect of lightning strikes.

There are a number of ways in which electrical supplies on plants are derived but a very common system is that illustrated in figure 6. The electrical power for the installation is fed at some relatively high distribution voltage from the grid system and connected at the plant by a distribution transformer which provides a 440V 3-phase star-connected system. The centre point of the star is the system neutral and is connected to a specially

constructed mat which connects to the ground. This connection provides a return path for any fault current which is derived from the grid distribution system. The return path is not well defined. The route may be via the pylon earths, the protective conductor and any other electrical conductor which happens to be convenient. The impedance of this path is not too critical since the high distribution voltage will drive a detectable current through a relatively high resistance connection.

A secondary effect of referencing the neutral to ground is to provide a parallel return path through the ground for any fault currents which would normally flow through the structure. It is not usual to rely on such paths for electrical protection in hazardous areas since they are not well defined. If for some reason part of a plant is not adequately bonded, then if it makes some connection to the ground it becomes partially protected. This is not a satisfactory state of affairs but is preferable to having no interconnection.

In general, with the possible exception of lightning protection which is discussed in the next section, the connection to ground is not important in discussing electrical protection on hazardous plants.

## 7 Lightning

This enthralling subject is worthy of considerable discussion and a much fuller picture can be derived from reading the application notes produced by Telematic Ltd and listed in the references at the end of this document. A brief analysis follows which

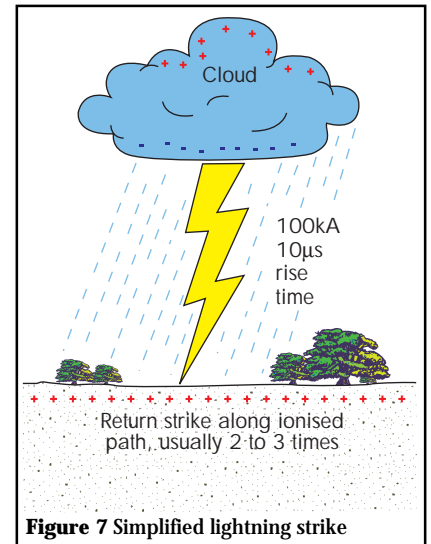


Figure 7 Simplified lightning strike

attempts to show the interaction between lightning bonding and grounding and other related bonds.

The primary cause of the problem is the down-strokes between the electrostatic charge generated in the lower part of thunder clouds (usually cumulo-nimbus) and the corresponding induced charge in the ground as illustrated in figure 7.

The magnitude of the current and its rate of rise are both important: a typical strike is 100kA, rising to its maximum in 10µs. If this current strikes a vertical structure such as a storage tank as illustrated in figure 8, and if the tank inductance is of the order of 0.1µH/m, then the voltage gradient in the structure is 1kV/m.

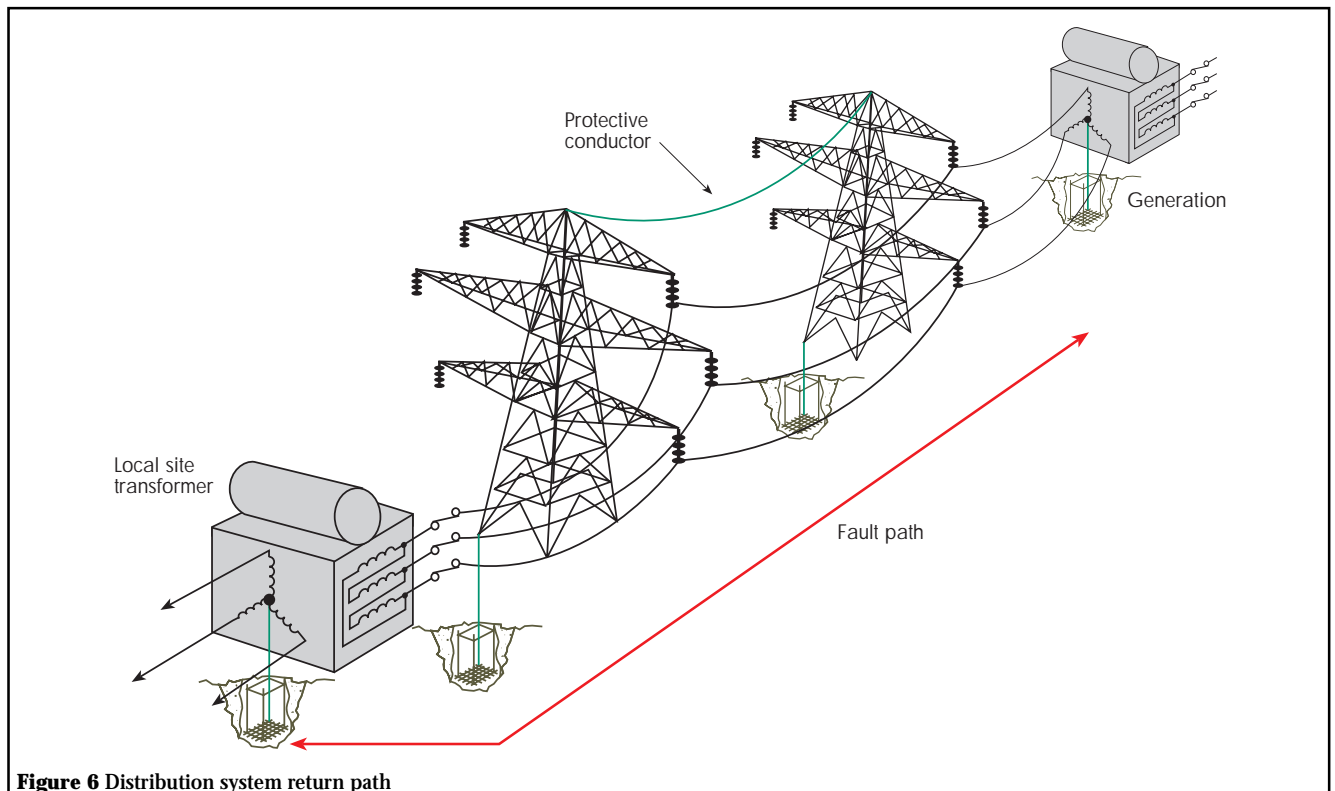
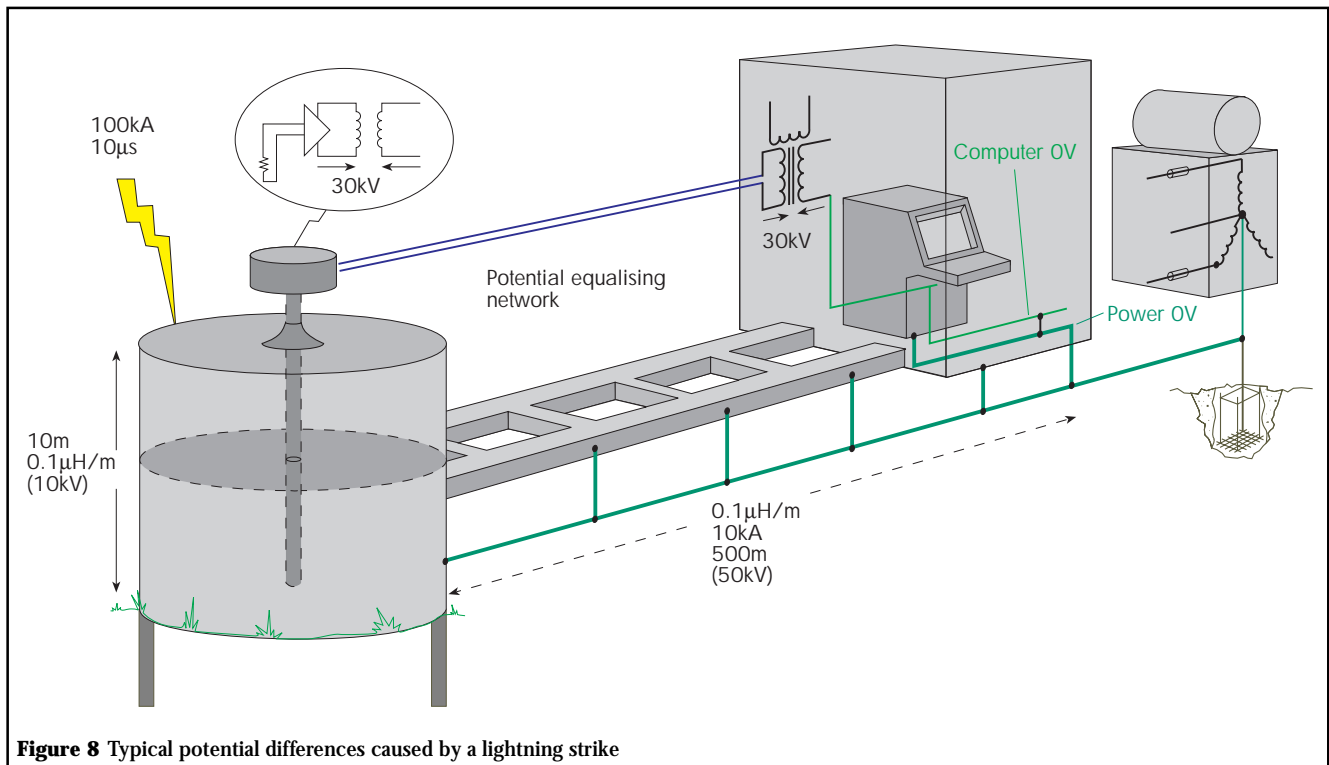


Figure 6 Distribution system return path



**Figure 8** Typical potential differences caused by a lightning strike

Side flashes are associated with voltages of 5kV or more and plant must be bonded to adjacent structures at intervals of less than 5 metres. Conventionally the low frequency or dc resistance of lightning conductors is measured but in practice, with rapidly rising current discharges, it is the inductance of the structure or conductor which matters.

The usual practice is to provide tall structures such as fractionating columns with a good connection to ground (usually inherent in the construction of the column) and assume that the major portion of the lightning strike (90%) disappears into the ground. This does not appear to be always the case since quite frequently the ground has a very high resistance and the current dispersion is not easy to predict, but follows different paths with a magnitude determined by the relative impedances of available circuits. The simplified model usually chosen is as illustrated in figure 8 and although the currents and consequently the voltage gradients are smaller in the horizontal plane, the cross-bonding must be maintained to avoid significant potential differences.

The susceptibility of a plant to lightning strikes is primarily decided by its location. Transiently a plant has currents and voltages capable of causing ignition during a lightning strike. Where the probability of a flammable mixture of gases is high, i.e. in a Zone 0, then particular care to maintain a Faraday-cage type of protection is desirable. In other zones, precautions to avoid side flashes are necessary and the transient risk accepted.

Transient protection of instrumentation and other sensitive services is necessary from both an operational and safety viewpoint and this is discussed later in this document. The level of precaution to be taken is a balancing of the likelihood of a lightning strike and the possible consequences of equipment failure measured against the cost of installing surge protection.

## 8 Static electricity

The avoidance of potential differences created by static electricity which could result in ignition capable sparks is a necessary requirement of a hazardous plant. The predominant hazard is not from electrical equipment but from materials being handled on or used in the construction of the plant.

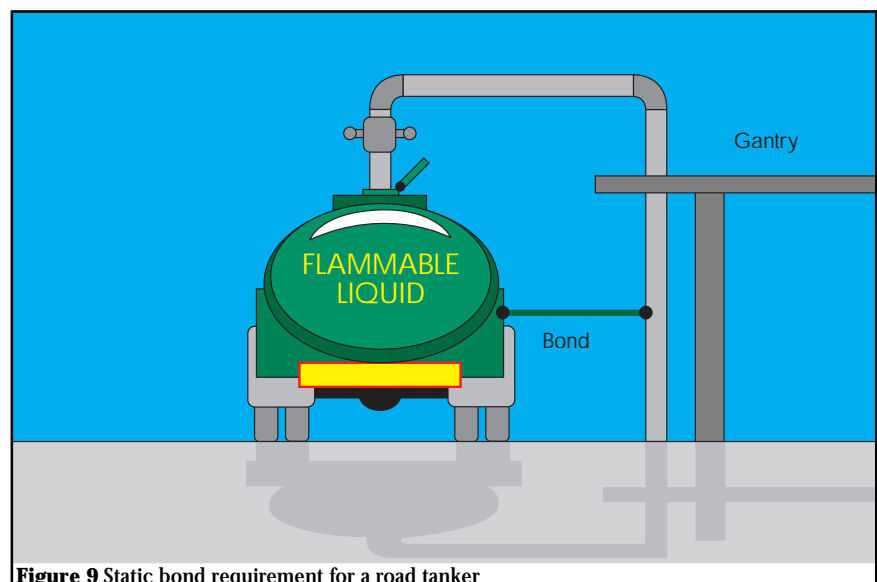
Static is invariably generated by charge separation occurring as a result of intermittent contact between non-conducting materials. Such separation can frequently be avoided by using materials which are partially conducting. Some commonly used materials such as petroleum frequently contain antistatic additives. Non conductive fluids or powders in motion are a frequent cause of static, which is more easily generated as the velocity of movement is increased. As eddies and turbulence increase there is a marked increase in static generated. Anything which generates discontinuities in the flow – such as filters,

control valves or sudden changes in pipe cross-section – is detrimental.

The removal of static is usually accomplished by providing a return path which recombines the separated charges. The requirement is usually met by bonding together all the electrically conducting parts of an installation.

Figure 9 illustrates the bonding system necessary for filling road tankers where static problems can exist due to vehicle movement and the transfer of hydrocarbons. There are problems associated with making the initial connection without creating an incendive spark, and also providing a monitoring system which cannot readily be bypassed.

The General Requirements of the CENELEC standards for electrical apparatus require that outer enclosures which are plastic should have antistatic properties and where this requirement cannot be met then they should be labelled so as to avoid the generation of static when they are cleaned or subject to



**Figure 9** Static bond requirement for a road tanker



friction. In many locations the presence of high humidity and conducting dirt and salt encrustation makes the creation of static extremely unlikely. In some clean and dry locations, particularly where insulating powder is available, then static is a real risk and adequate precautions must be taken.

Except where special mechanisms exist, it is difficult to draw a heavy spark from an insulating surface since the amount of charge which is extracted by a point approach is limited. A much more dangerous situation is created by having a conductive piece of metal, which is not bonded to the adjacent conductive surfaces, mounted on the insulating material. This piece of metal (e.g. a metallic foil label) can become charged and the resultant capacitor discharged by a short circuit to the adjacent surface (a voltage of 5kV stores sufficient energy to ignite hydrogen in a capacitance of 1.6pF).

For a more comprehensive treatment of the risks due to static one of the best sources of information are the current British Standards. A CENELEC document is in the course of preparation and is worth studying if you have access to such material. It will eventually be published as an EN.

## 9 Interference avoidance

This section concentrates predominantly on low-frequency interference since this is the principal source of problems in the process control field. Recently there has been an increased awareness of the interference aspects of electrical equipment as a result of the European Community Directive on the subject and the emergence of numerous related IEC standards. In the long term this may result in equipment which radiates less interference and is less susceptible to other sources of interference.

The major cause of interference which is usually considered is the effect of magnetic coupling between cables. This does not cause many problems in hazardous plants, since almost all electrical power is provided via cables which carry current to and from the load and hence generate only a limited magnetic field.

Invariably the power cables are armoured cable and the ferrous armour creates an effective magnetic screen. In theory an effective electromagnetic screen operates by allowing the magnetic field to generate a current in the screen which generates its own magnetic field which almost cancels the initiating magnetic field. For this process to function there is no necessity for the screen to be bonded. It is however normal practice to do so in order to utilise the magnetic screen to provide capacitive screening and also to determine its electrostatic potential.

In almost all structures there is a significant current caused by the parasitic capacitances which inevitably occur in all electrical apparatus. The problem can best be illustrated by considering the capacitive current from apparatus such as high voltage 3-phase electric motors. A typical motor will have a

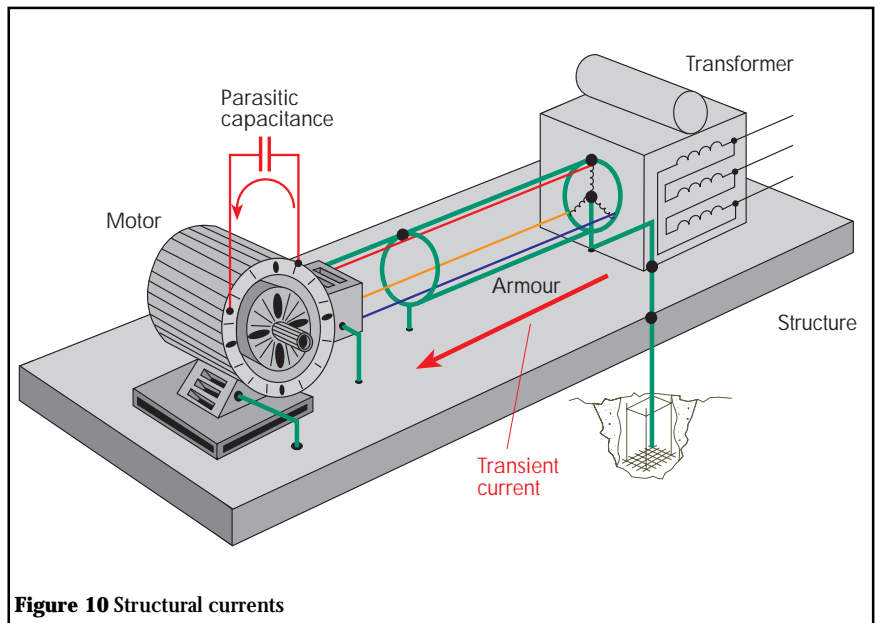


Figure 10 Structural currents

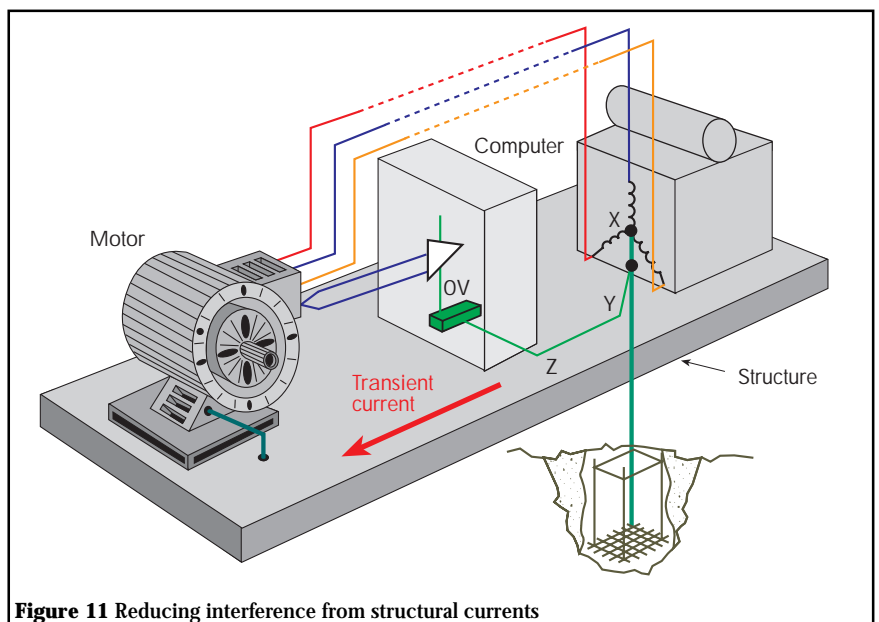
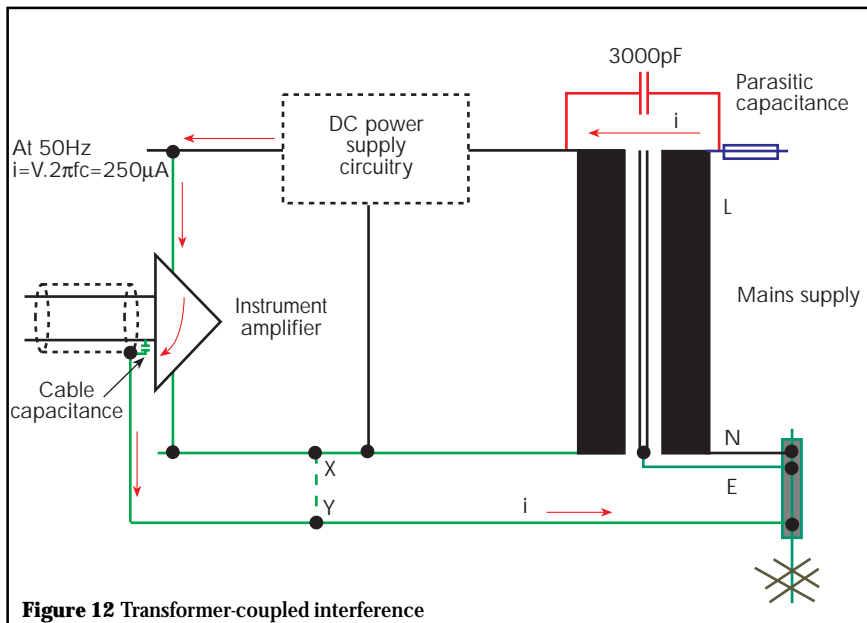


Figure 11 Reducing interference from structural currents

significant capacitance between its windings and structure as shown in figure 10 and the current which flows through this capacitance will be of the order of 100mA in normal operation, with a significant third harmonic content. The majority of petrochemical installations have currents of 300 to 400mA circulating through them. When the motor is switched on, this capacitance has to become charged and the current to achieve this is quite high for a very short time (6.6kA for 10µs). In general, the currents arising in normal operation do not cause a major interference problem but the high transient currents generated by switch-on can cause significant problems.

Commonly, sensitive circuits are bonded to the structure at one point so as to avoid some of this structural current circulating through the sensitive circuit. The general principle is therefore to bond sensitive circuits to the equipotential plane at one point only and to choose the point carefully so that the current return paths do not share a common path with the structural currents. The principle to be followed is illustrated in figure 11.

The transient current to charge the motor capacitance flows through the structural bond back to the neutral star point. If the 0V of the computer is returned to the neutral star point Y then the common mode voltage generated by the surge current is across the relatively small impedance XY and is possibly acceptable. However if the computer 0V is connected to the structure at the point Z then the common mode voltage is related to the large impedance ZX and hence usually causes difficulties. The problem associated with multiple bonds to the structure is illustrated by the thermocouple which is in contact with the motor. If the amplifier does not have isolation between the input and the computer 0V, a proportion of the transient structural current will flow through the parallel path created. Since the current flows through the sensitive input circuit of the amplifier it will cause a measurement problem or could possibly damage the circuitry.



**Figure 12** Transformer-coupled interference

The problems of multiple earthing should not be exaggerated and are predominantly operational. A conductor in parallel with a well-bonded structure will carry only a part of the structural current (tens of milliamps continuous). It is not likely to become hot or generate an incendive spark when broken because it will have a low inductance. Multiple earthing of intrinsically safe circuits is not permitted because of the ill-defined nature of the resultant circuits and only partially because of concern that such a circuit could be hazardous.

The primary cause of low frequency interference within electrical equipment is also stray capacitive currents. It is necessary in all electronic equipment to provide a well-defined return path for any unwanted currents which are induced into the circuit. The predominant problem is created by capacitance between the primary and secondary of mains transformers and is illustrated in figure 12.

In modern circuits using switch-mode power supplies the inter-winding capacitance is much smaller but the frequency is higher, hence the problem is still significant. The currents are relatively small (250µA) and provided a well-defined return path is available through the less sensitive parts of the circuitry via the link XY, they cause no problem. If however this link is omitted then this current may follow the path indicated, through the sensitive input circuit,

field wiring and capacitance to the wiring screen, creating an interference problem. Because this problem is increased by the connection of the field wiring it is frequently mis-diagnosed as being caused by pick-up in the field wiring. The cure is however to securely connect the 0V rail of the computer to the neutral star point, thus providing a return path for these currents and also providing a well-defined electrically quiet reference potential for the computer.

There is usually a small current induced in the field wiring. A possible form is illustrated in figure 13. If screened cable is used then the unwanted current can be returned to the neutral star point without passing through any sensitive part of the circuit. If unshielded cable is used then the unwanted current impinges upon the field wiring and finds its way back to the neutral star point via the sensitive input circuitry of the computer, which creates an interference problem.

The interference current is small and hence the return path does not need to be of low resistance. However the earthing lead is normally made robust for mechanical reliability reasons. If screened cable is used for safety reasons then the screen and its earthing cable have to be sufficiently electrically robust to carry the possible fault current for sufficient time to ensure that the fault is cleared. In

practice, the use of a robust cable (10mm<sup>2</sup>) does not increase the installation cost appreciably and avoids the need to deeply consider all the possible implications.

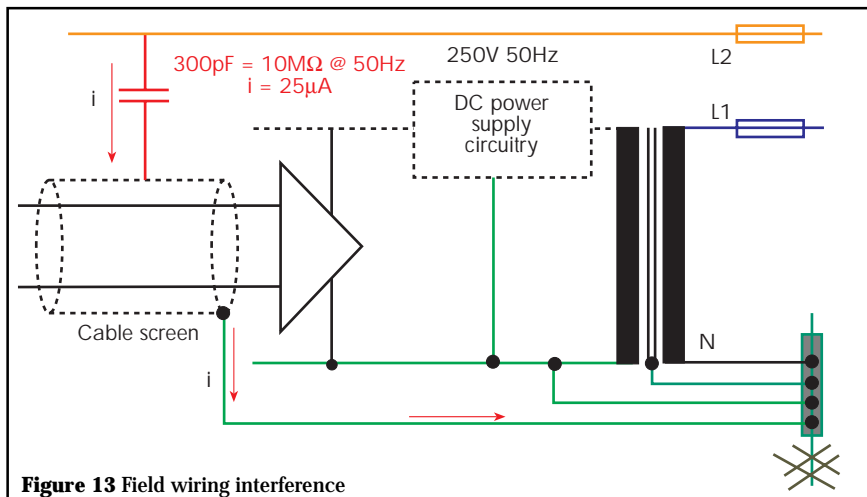
## 10 Explosion-proof equipment

All explosion-proof equipment relies for its safety integrity on being adequately electrically protected so that electrical overloads do not generate excessive heat or incendive sparks. This document concentrates on intrinsic safety, where there tends to be more emphasis on the requirements of electrical protection and earthing. This is largely because of historical background to the development of the technique but is justified to some extent because of the use of intrinsically safe equipment in the more hazardous location of Zone 0. The possibility of working on circuits without isolating them and the requirement that some monitoring equipment has to remain functional in the presence of major gas releases or catastrophic circumstances also leads to further concern.

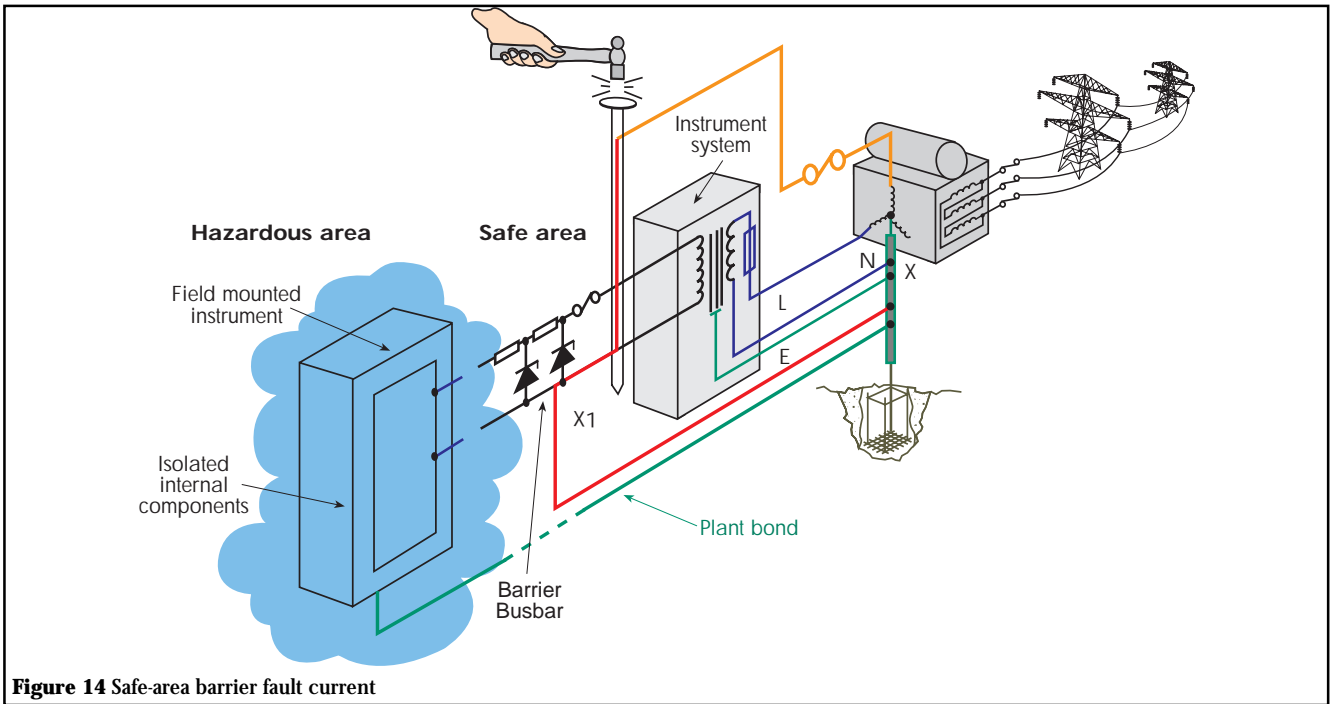
The earthing of shunt diode safety barriers illustrates the fundamental requirements very well and hence is discussed in considerable detail. The shunt diode safety barrier was introduced to remove the necessity to certify complex safe-area equipment. It is designed to permit the normal operation of the circuit, and if a fault occurs within the safe-area equipment it should prevent the passage of a level of energy which can cause ignition or a level of power which can cause excessive temperature rise. A more detailed description of the operation of shunt diode barriers and also galvanic isolators is given in TP1113 'Shunt diode safety barriers and galvanic isolators – a critical comparison'.

The protection technique of shunt diode barriers is illustrated by figure 14. A fault current derived from the mains phase voltage invades the safe-area side of the barrier. Part of the current may flow through the fuse of the barrier, rupturing it; but a significant part of it would flow through the 0V rail of the barrier system, being limited in magnitude only by the impedance of the fault circuit, and its duration determined by the fuse or other fault-current limitation protecting the phase providing the fault current. The return path provided to the neutral star point ensures that the fault current does not enter the hazardous area, by presenting a lower-impedance path along which the current prefers to flow.

Barrier-protected intrinsically safe circuits are earthed at the barrier busbar only, and elsewhere are insulated from the plant structure. The field mounted instrument illustrated in figure 14 would normally have its enclosure bonded to the structure and its internal electronics isolated from the case and directly connected to the barrier. (The level of isolation required is to be capable of withstanding a 500V test. It is however advisable to avoid doing a 500V test on an installation where there is any possibility of a flammable gas being present).



**Figure 13** Field wiring interference



**Figure 14** Safe-area barrier fault current

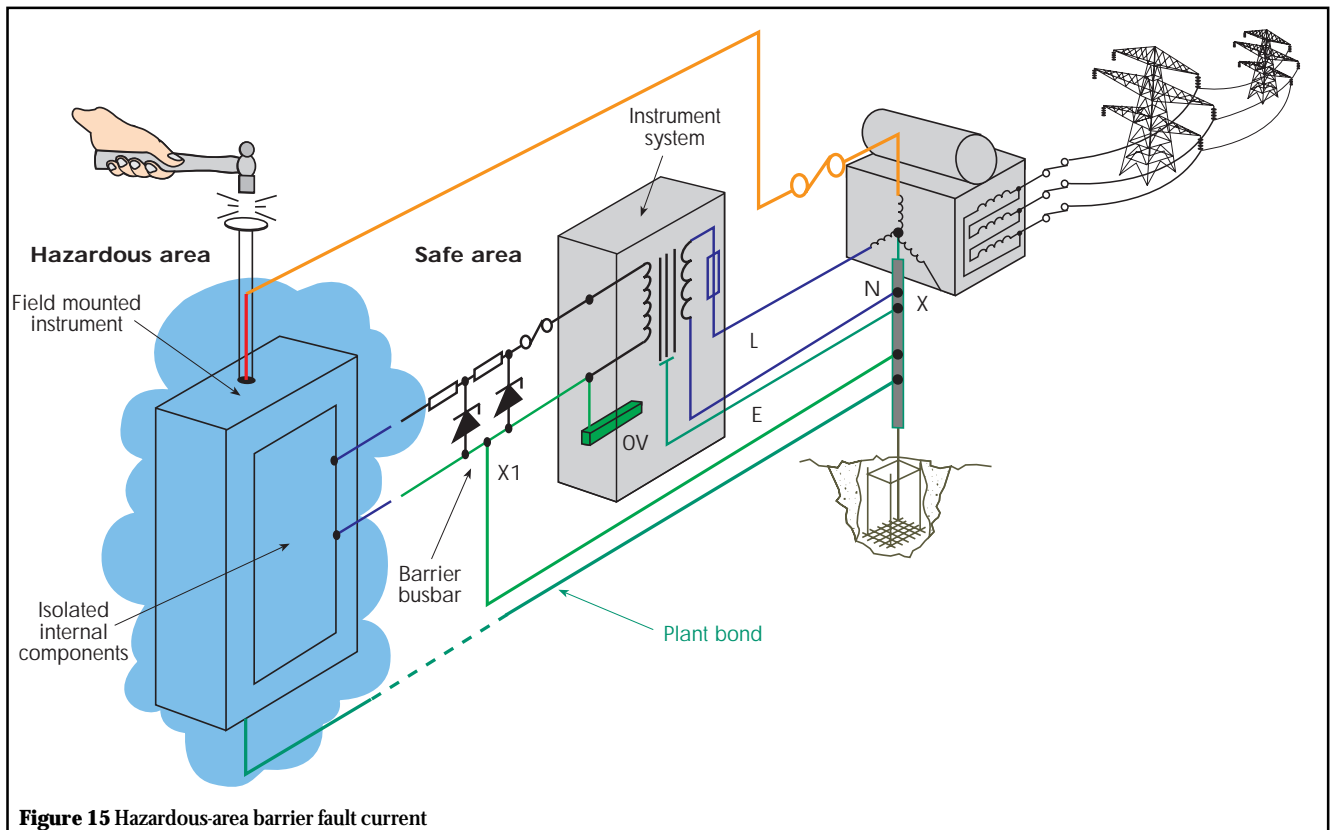
During the short time that the fault current is flowing, a voltage drop occurs in the return path between the points X1 and X. This voltage difference is transferred to the field mounted instrument since the enclosure is bonded to the structure at the same potential as the point X and the internal electronics directly connected to the point X1. Since this voltage difference occurs in the hazardous area it is desirable that it should be less than 10V so that the probability of an incendive spark is acceptably low. If the fault current from the 240V supply is 100A (a fault circuit impedance of  $2.4\Omega$ ) then the impedance between X and X1 should be less than  $0.1\Omega$ . It is important to recognise that this is the resistance of the conductor between the barrier busbar and the neutral star point. The resistance of the

connection to ground is not important since the fault current does not return to ground, it returns to the neutral star point. Various codes of practice suggest that a value of  $1\Omega$  is acceptable but this is possibly too high. The lower value is usually readily achievable, since the barrier earth connection is always quite short and is a robust cable to ensure its mechanical integrity. For example, a  $10\text{mm}^2$  copper conductor has a resistance of  $2.8\text{m}\Omega/\text{m}$ . Hence a 25m cable would have a resistance of  $70\text{m}\Omega$  and so would satisfy the requirement.

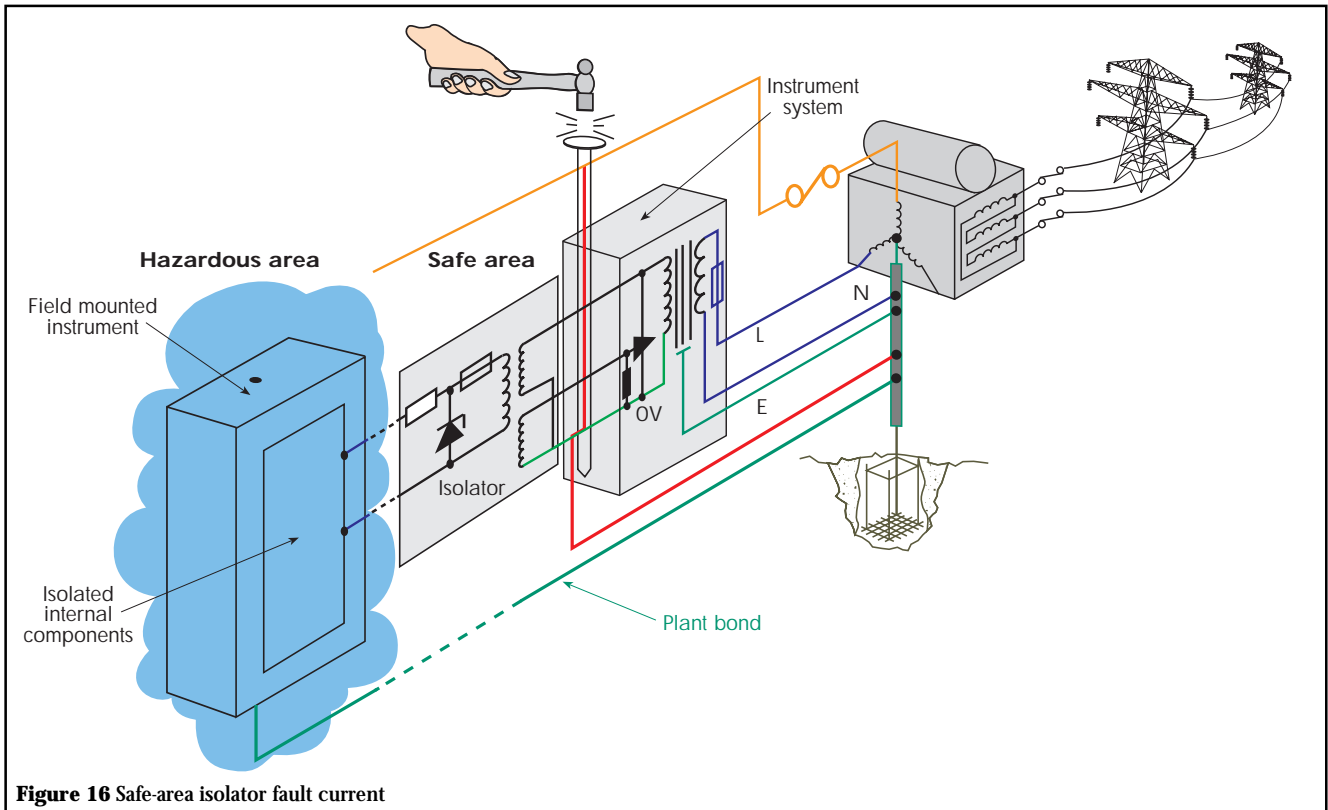
It is interesting that a mains supply fault in the hazardous area, as illustrated in figure 15, produces a similar potential difference created by the fault current flowing through the plant structure. The multiple return paths and cross

bonding must create a low resistance return path of the same order as the barrier earth conductor so as to avoid significant voltage differences.

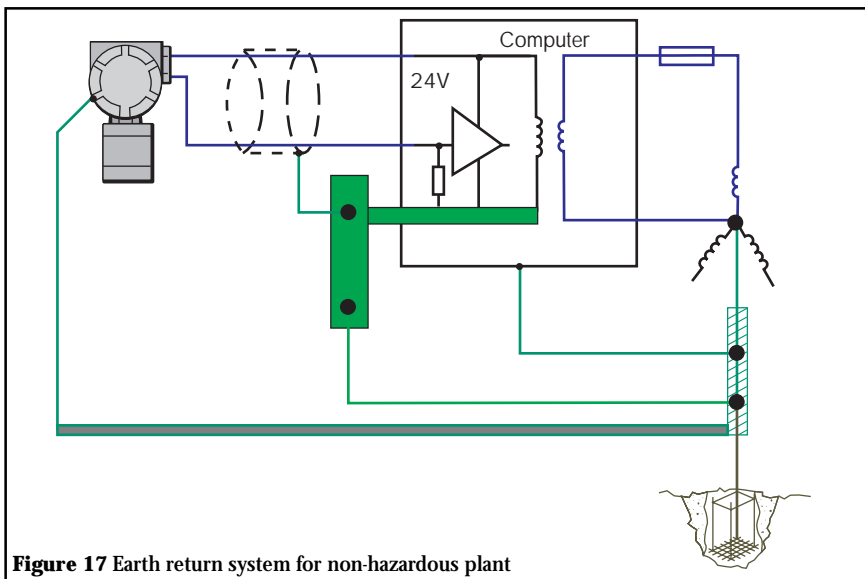
The use of galvanic isolators as interfaces changes the earthing requirements from being a primary contributor to the method of protection, to a secondary one. Figure 16 shows the fault being removed in a relatively short time by having a well-defined return path on the safe-area side of the isolator. Voltage elevation of the safe-area side of the isolator is not transferred to the hazardous area, but a prolonged mains fault would damage the components on the safe-area side, or more probably damage the computer input circuit. In these circumstances the earth return is not vital to safety and is primarily essential for operational and electrical protection reasons.



**Figure 15** Hazardous-area barrier fault current



**Figure 16** Safe-area isolator fault current



**Figure 17** Earth return system for non-hazardous plant

### 11 Combined earthing for interference avoidance and intrinsic safety purposes

In almost all circumstances the 0V rail of the computer and the barrier busbar are linked by the method of measurement and hence the earth returns are combined.

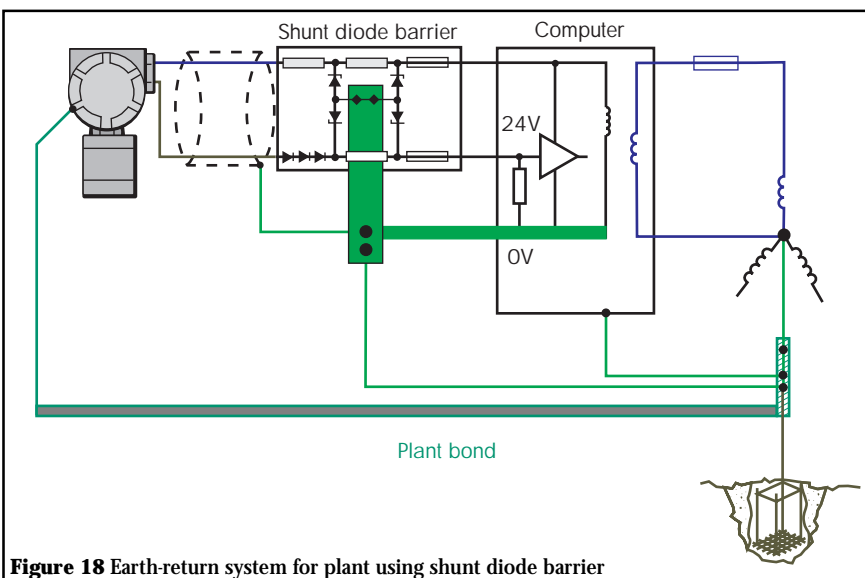
Fig. 17 reiterates the normal practice of returning the computer 0V and the screens of the field wiring separately from the structural and power system to the neutral star point. This system ensures a defined fault return path for any power faults or induced interference currents and prevents the power system currents generating a common mode voltage on the 0V rail of the computer.

The introduction of the shunt diode barrier does not appreciably change the circumstances, as illustrated by figure 18. The earth returns are combined by linking the computer 0V rail and screens to the barrier busbar, and the earth return path should meet the resistance requirement of at least  $1\Omega$  but preferably  $0.1\Omega$ .

When isolators are used, the barrier busbar is omitted and the screens of the field wiring are connected to the 0V rail of the system as indicated in figure 19.

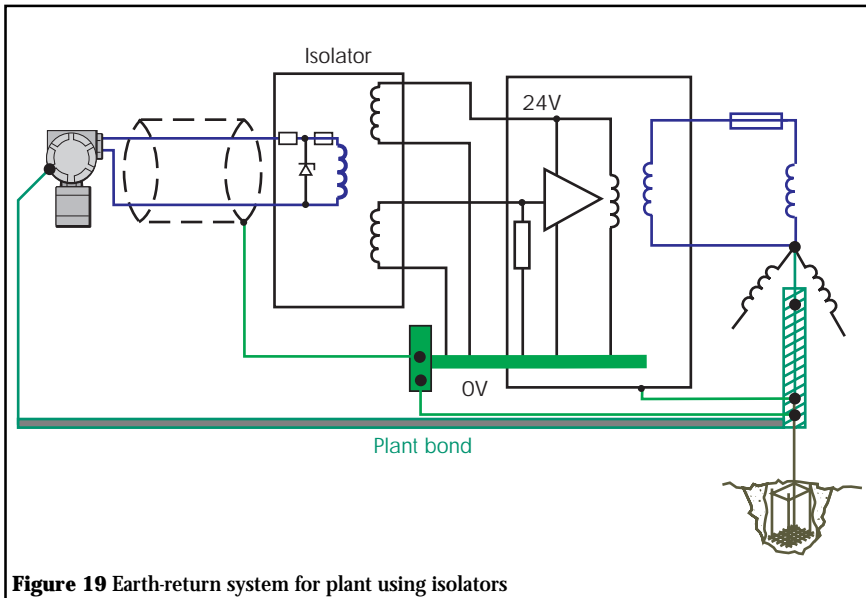
In these circumstances the earth return from the 0V rail has to be of the same standard as for shunt diode safety barriers since the transient potential differences developed across it appear as voltage differences between the cable screens and the structure within the hazardous area.

Protection against transients caused by lightning and power surges also impinges upon earthing and bonding requirements. A simplified view is that surge protection devices (SPDs) act in much the same way as shunt diode safety barriers in that they protect equipment by

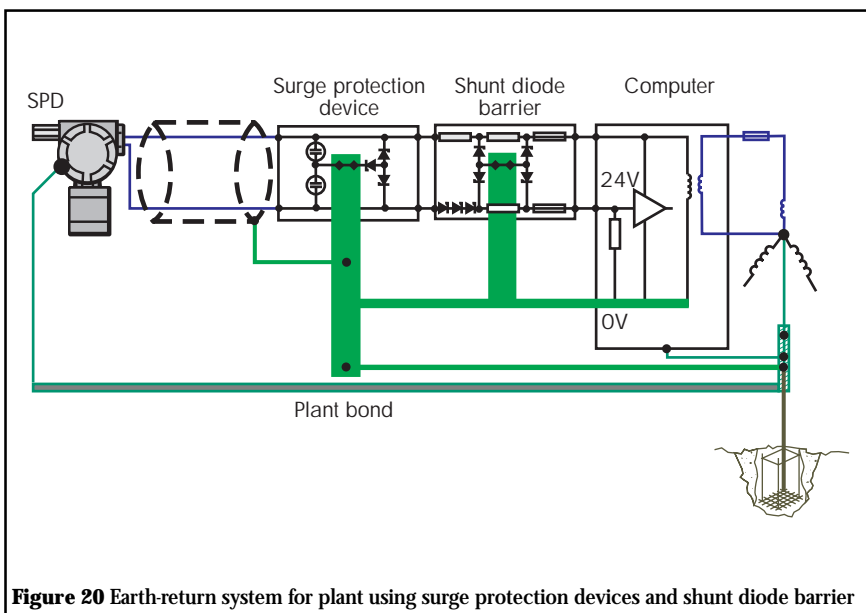


**Figure 18** Earth-return system for plant using shunt diode barrier





**Figure 19** Earth-return system for plant using isolators



**Figure 20** Earth-return system for plant using surge protection devices and shunt diode barrier

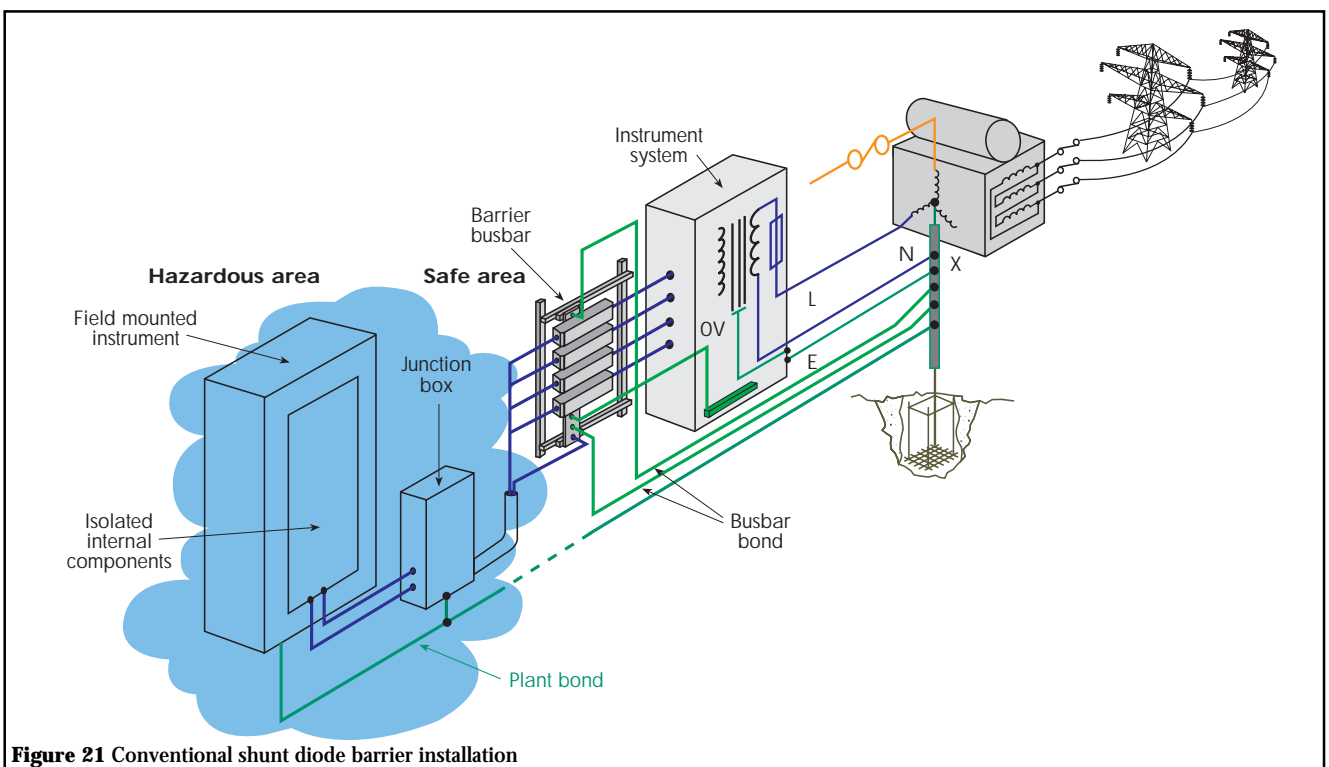
providing an alternative path for the surge current, and limit the differential and common mode voltages applied to the apparatus. The subject is dealt with comprehensively in the Telematic Ltd application notes listed in the bibliography and these should be studied if lightning surge damage is considered to be a significant problem. The solution normally adopted is to use the lightning surge suppressor earth return to establish the 0V of the system as illustrated in figure 20. The safe-area and barrier circuits are bonded to the surge suppressor to prevent any differential voltages being established. In these circumstances the fast rising edge of the surge current may cause some common mode problems if the return path has significant inductance, and hence the length of the grounding conductor should be minimised.

## 12 Practical consideration

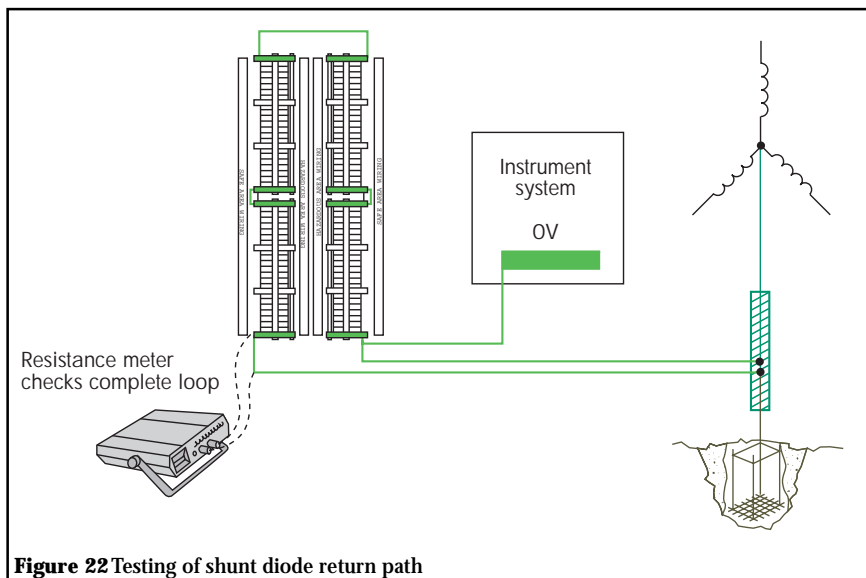
The conventional installation becomes as illustrated in figure 21 with the barrier busbar and computer 0V insulated from the structure and returned separately to the neutral star point bond.

It is normally a requirement that the barrier busbar return path be periodically checked. This check is much easier to do if the connection is duplicated as shown in figures 21 and 22. If this is done then an accurate resistance measurement can be made by disconnecting one lead and inserting a low-voltage meter in series with the resultant loop. (Note that the loop resistance is four times the parallel resistance of the normal installation). A record of this measurement should be maintained and any instability in the readings investigated. A great advantage is that such a check can be done without a major disturbance of plant function.

The two connecting wires need to be routed close to one another but should form an effective ring main as shown in figure 22. Concern is frequently expressed about the resultant loop generating a magnetic pick-up problem, but



**Figure 21** Conventional shunt diode barrier installation



**Figure 22** Testing of shunt diode return path

considerable experience suggests that this is not a practical problem. The earth return lead needs to be identified and a common practice is to bind the two leads together with blue insulating tape at frequent intervals so as to distinguish them from other similar conductors.

With this type of installation it is worthwhile to measure the resistance between the busbar and the cabinet, since this is an indication of the effectiveness of the structural bond. If facilities are available a note of the voltage waveform existing between the structure and busbar should be made. This waveform is frequently an indicator of deterioration in the structural bond or the introduction of interference-generating equipment. Frequently a knowledge of this waveform is useful in diagnosing problems.

Some care has to be taken that the terminals used for earth connections should be of high quality and vibration-proof. The best practical solution is to use the terminals that are suitable for increased safety (Ex e) installations. It is permissible to carry critical earth connections via plugs and sockets, but three strategically placed pins must be used and some precautions taken to prevent disconnection without first removing power from the protected installation.

### 13 Screens and armour

The basic principle to be observed is that screens are bonded to the equipotential plane at one point only and elsewhere are to be adequately insulated. The usual practice is to bond the screen at the safe area and frequently at the barrier busbar as illustrated in section 11. Bonding the screen at one other point is not however prohibited and appendix 1 explores some other possible variations of cable construction and the use of screens.

When screens are used to guard against pick-up from high frequencies, they are usually earthed at a number of points so as to prevent the screen presenting a tuned aerial to the high frequency. For intrinsically safe circuits with this problem the acceptable solution is to include 1000pF capacitors to ground at convenient points such as junction boxes. These effectively detune the screen but do not provide a path for the low frequency currents which can cause interference

problems if they are permitted to flow in the screen. Since a screen and its enclosed cable are effectively coaxial, the effect of currents in the screen is not as great as might initially be expected.

Screens have frequently to be terminated in junction boxes without bonding them to the structure. The preferred technique should be to make off the screen into a suitable ferrule and use a terminal block to ensure that it remains secure and isolated. This also provides a useful 0V facility within the junction box which simplifies some aspects of fault finding. Other techniques are permissible but are usually less satisfactory.

Unused cores within cables are treated in the same way as screens, being usually connected to the safe-area 0V system and insulated at the field end. These cores should always be terminated in a terminal so that if they are used at some future time they can readily be connected.

The capacitance of a cable, which is used when calculating the energy stored in a cable for intrinsic safety purposes, is considerably affected by the presence of a screen. It is important that the higher value associated with a screened cable be used in making the safety assessment.

Where armoured cable is used for intrinsically safe systems, then it is acceptable practice to regard the armour as primarily for mechanical protection. It therefore becomes part of the plant structure and hence can be multiple-bonded. Bonding is usually achieved by using conventional glands which connect the armour to the structure whenever they are used. This does mean that the armour will carry a part of the current which flows in the structure.

### 14 The use of separate earths

There is a strong body of opinion which advocates the use of separate groundmats for instrument systems, computer 0V, power systems and lightning. This separate-earth theory generates numerous expensive grounding systems which have to be isolated from one another or interconnected by zero impedance depending on which problem has to be solved.

The problem with trying to refute this strange arrangement is that in some circumstances it appears to have beneficial results.

The system which is frequently advocated is the connecting together of all the sensitive 0V connections of instrument systems and connecting them to a separate earth rod as illustrated in figure 23. The capacitive interference currents discussed in section 9 then flow down the separate rod and at some point transfer into the power system earth mat and return to the neutral star point via the interconnecting cable. The discipline of connecting together the sensitive 0V connections and separating them from the structure is beneficial from an interference viewpoint and the impedance of the return path is not critical since the currents are small. The system however functions because the currents are returned to the neutral star point and this can be achieved much more reliably and economically by returning the 0V of the system to the neutral star point at the point X, as advocated elsewhere.

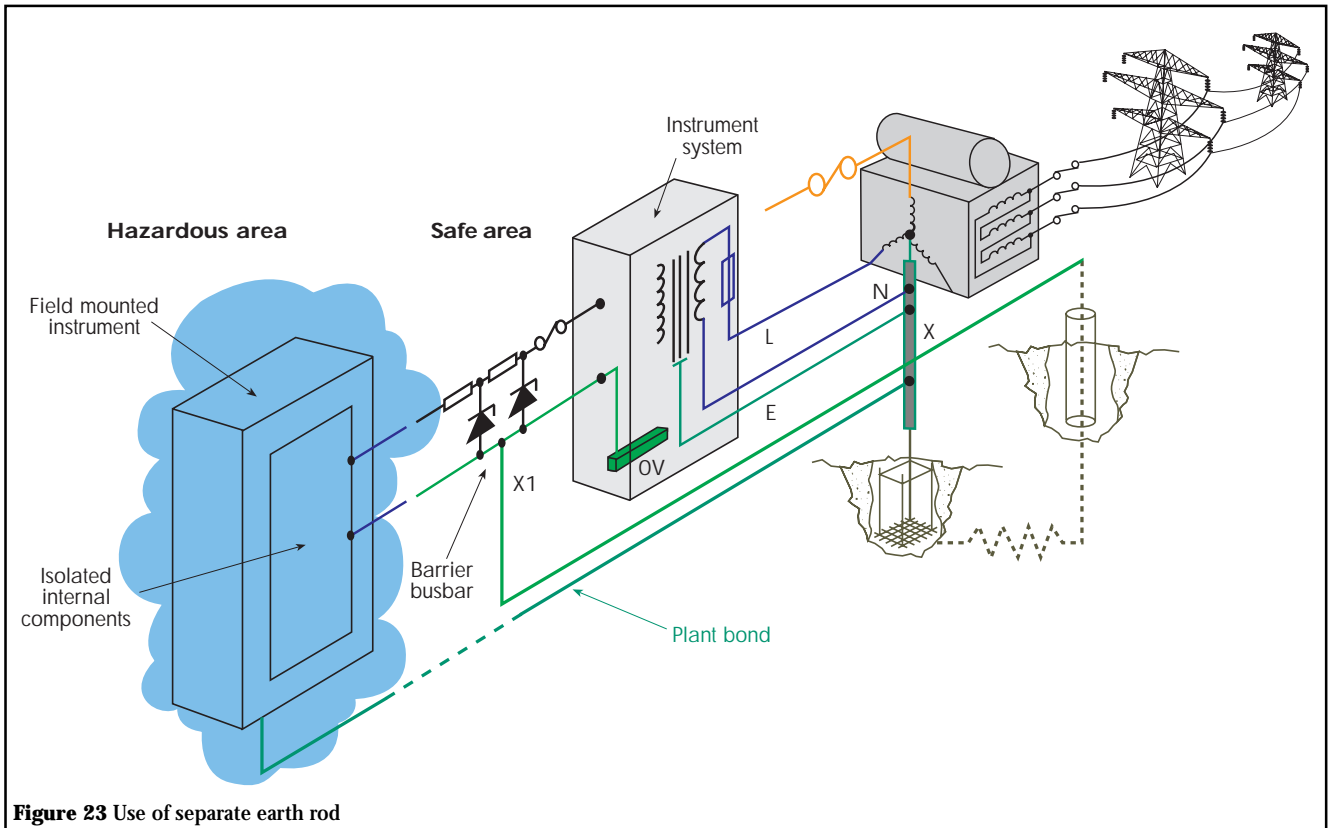
In an instrumentation system without barriers a power fault to the 0V system has to be cleared by the current which passes between the two earth mats. The indeterminate resistance between these mats may not be low enough for the protective system to operate. When a system uses shunt diode safety barriers (as in figure 23) then the resistance of the return path cannot achieve the 1Ω level demanded by most codes of practice and certainly will not approach the desirable level of 0.1Ω. The separate earth-rod system is therefore generally not adequate with power faults, and is not acceptable for any hazardous-area installation.

There is a much greater problem if there is a significant probability of the installation being struck by lightning. If the lightning and instrumentation earths are not cross-bonded, then the possible series-mode potential applied to the instrumentation system can readily be demonstrated to be hundreds of kilovolts for a relatively modest lightning strike. Some earthing systems use low resistance high frequency chokes between earths but their use without some voltage limiting device across them is difficult to understand.

The use of separate earth rods is not justified in process control installations. If they are insisted upon by the computer or instrumentation 'expert' then the obvious question to ask is how do computers operate on aeroplanes and ships where a single ground connection is not possible and two separate connections to ground create problems for even the most vivid imagination? The fundamental requirements are therefore for bonding to prevent voltage differences, and for well-defined current return paths for interference rejection and electrical protection.

### 15 Location with remote neutral star point

There are situations where the neutral star point is some considerable distance away from the point at which the barriers are installed and in these circumstances there could possibly be a large voltage between the plant bond potential and



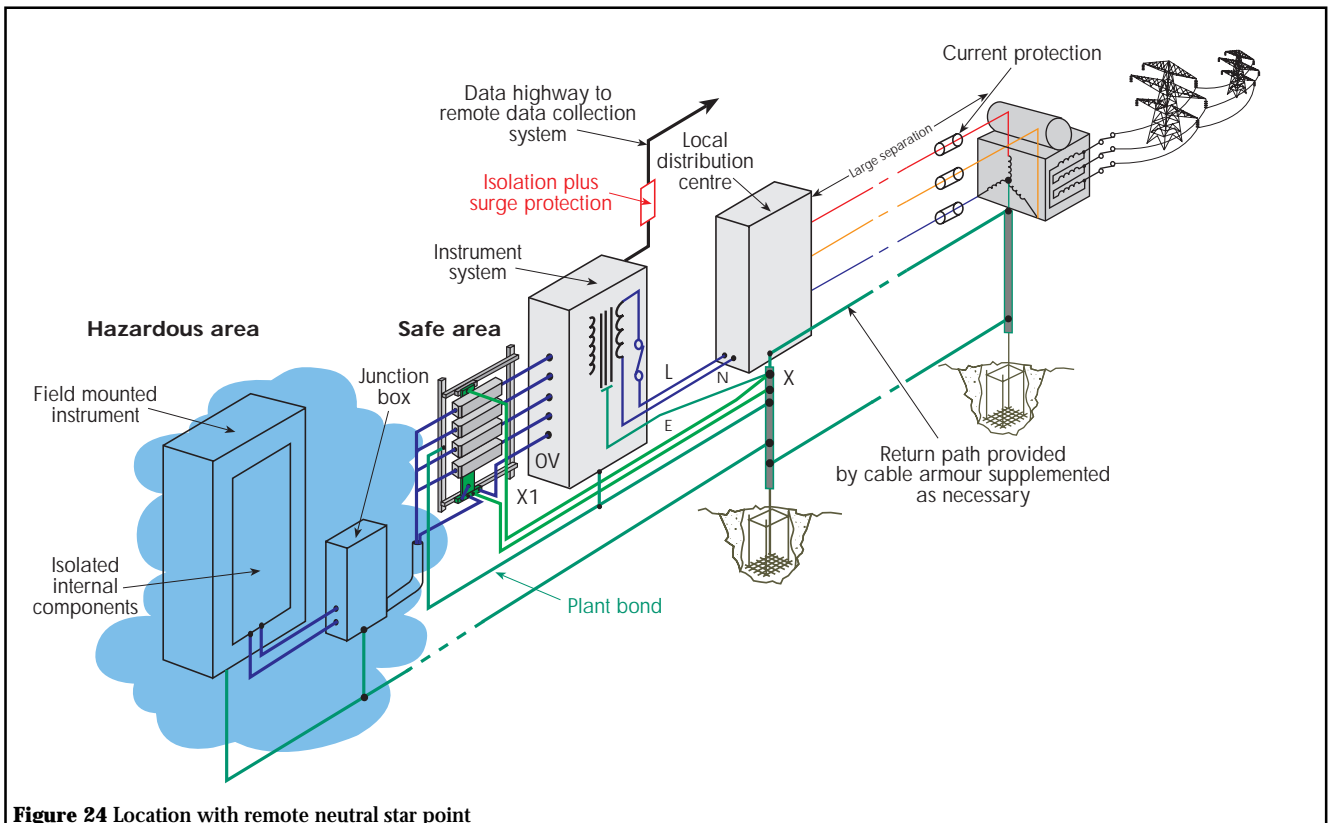
**Figure 23** Use of separate earth rod

the neutral star point. A typical installation might be a remote tank farm with only a limited requirement for power. Such a location would usually have a local distribution centre which would have a local earth mat which sets the potential of the local earth plant as illustrated in figure 24. The supply to the distribution centre has a fault return path to the neutral star point, provided by a specific conductor, the cable armour, and supplemented by an ill-defined path between the earth mats. Even with sensitive overload protection a modest fault current would generate a significant fault

voltage between the neutral star point at the distribution transformer and the plant reference potential at the local distribution centre. This potential difference is evenly distributed over a long distance and providing that the return path is sufficiently robust to avoid local heating, does not cause any problem.

The barrier busbar should in these circumstances be connected to the local distribution centre busbar, and not connected by an isolated lead to the distant neutral star point. This local connection ensures that no

large voltage develops between the plant structure and the instrumentation circuits. The  $0.1\Omega$  requirement applies to the connection between the barrier busbar and the local distribution centre ground. The return path to the neutral star point is still necessary for electrical protection reasons, but in these circumstances voltage drop across the return path does not affect safety. The final installation therefore complies with the two basic requirements of minimising the voltage differences within the hazardous area and having a secure return path for any fault current.



**Figure 24** Location with remote neutral star point

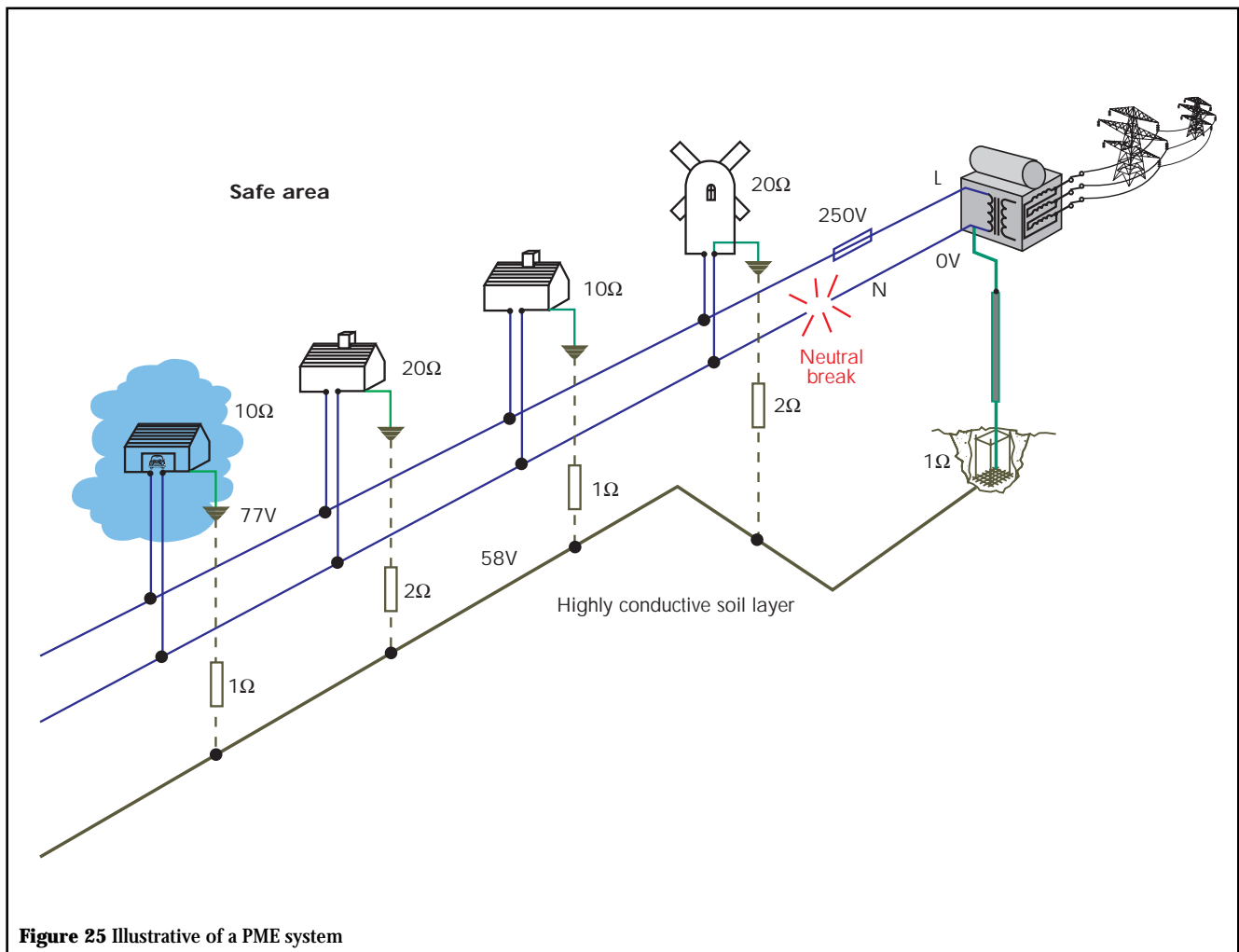


Figure 25 Illustrative of a PME system

Similar circumstances occur in numerous other situations. For example, when associated safe-area apparatus is mounted within flameproof enclosures then the circuits are usually bonded to the enclosure for optimum safety of the installation. In all circumstances, if an installation requires a long return path conductor from the barrier busbar, then it is being connected at the wrong point. The installation should be redesigned so as to minimise the fault difference voltage in the hazardous area.

## 16 PME (protective multiple earth) installation

In this type of distribution system the neutral return conductor and the protective bonding conductor are combined, largely to reduce the cost of the installation. Figure 25 gives a much-simplified diagram of a fairly complex and ill-defined situation.

The neutral is connected to the highly conductive strata in the ground via an earth rod at the distribution transformer, and also at each user installation, as illustrated. If all the connections are good (1 to 2Ω) and the system is working as designed, each user provides a load as indicated, the return current flows partially in the ground and partially in the neutral, and the system is reasonably safe.

There are many possible faults, but consider a break in the neutral at the point indicated. The loads and earth resistances in parallel are equivalent to 3.3Ω; the conductive soil rises to 58V with respect to the transformer earth rod and the garage earth rises to 77V. This in itself

is not dangerous, unless by some unsuspected route, e.g. the traditional wire fence on wooden supports, the reference potential can be transferred to the garage forecourt.

There are other possibly more frightening dangers if – coincident with a neutral fault – the other installations are not adequately earthed. In these circumstances all the fault current flows via the garage earth connection, probably the immersed storage tanks. The whole situation is so ill-defined that a safety analysis is very difficult and the very low probabilities of intrinsic safety fault counts become almost insignificant.

Because of the increased probability of mains surges on PME installations then consideration should be given to fitting a mains surge suppressor on all such installations.

On these installations safety must rely implicitly on the high-current capability, low-resistance bonding of the installation. The intrinsically safe system should be connected at one point to the PME system where the incoming neutral is connected to the local ground. Connected in this way, the intrinsically safe system does not modify the risk on the particular site. If instrument signals are transmitted from a PME site, then the outgoing signals should be isolated so that the site voltage distribution is not affected by the signal leads. Some consideration of the need to fit surge suppression should be given. This isolation should preferably be in a safe area on the site.

There are a few installations, usually when the electrical power requirements are low and the installation is remote, when fitting a power isolation transformer creates a much safer system from a PME supply. Figure 26 shows a gas pipeline outstation system which demonstrates this principle.

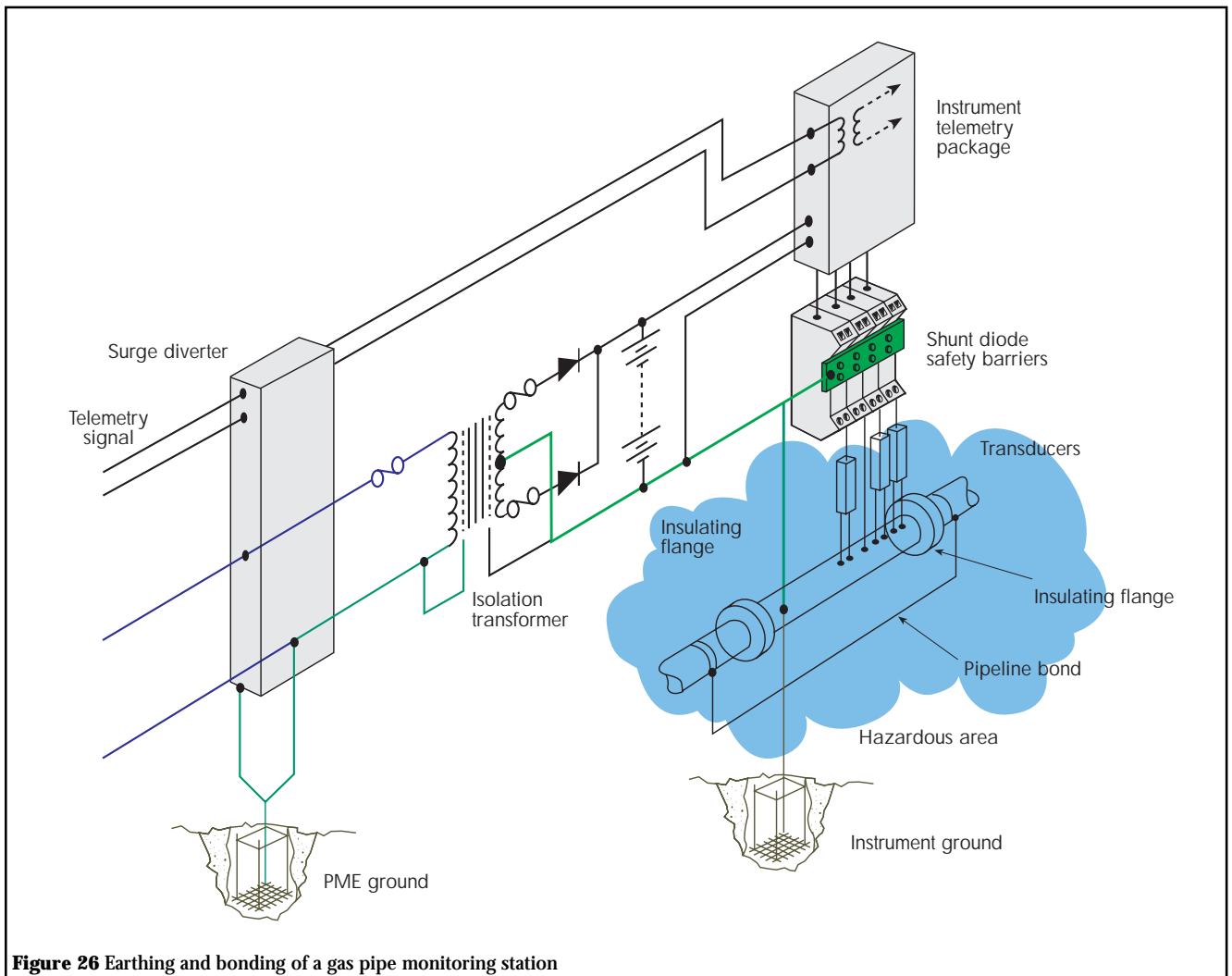
The PME earth connection must provide a reasonable connection back to the supply system or it does not comply with PME installation requirements. If possible it should be positioned a short distance away from the instrumentation point.

The PME supply on this type of installation will usually require to be fitted with some form of surge suppression.

The section of the pipeline being monitored should normally be isolated and an effective bypass should be connected to provide a path for any currents passing along the pipeline. The isolated section then becomes the reference potential for the hazardous area.

The section of the pipeline is frequently connected to an earth mat as shown, which in practice contributes very little and may confuse the cathodic protection being applied to the remainder of the pipeline. The barrier 0V is then referenced to the isolated pipe section and also returned to the centre tap of the isolation transformer so as to provide a return path for any fault current which flows.





**Figure 26** Earthing and bonding of a gas pipe monitoring station

If land lines are used for the telemetry system then some form of isolation is normally provided in the telemetry output and surge suppression applied as indicated.

In some locations remote outstations are powered by solar panels. This simplifies the situation considerably by removing the PME supply and the mains isolating transformer, but the interconnections are otherwise identical.

In these small tightly-bonded locations then there is little point in using isolated interfaces, and the use of barriers reduces the power consumption from the restricted battery supply.

### 17 Isolated intrinsically safe circuits

In some situations there is a historic preference for fully isolated circuits in intrinsic safety since an initial connection to ground would apparently have no effect. This is no doubt traceable back to the original bell signal transformer circuit. It is however possible that fully isolated circuits could be charged to a potential which would store sufficient energy in their capacitance to ground to make a short to ground incendive (0.01µF is incendive when charged to 200V in hydrogen). This apparently significant problem does not create a hazardous situation in practical installations, possibly because the majority of 'floating' circuits are held at or near to ground potential by stray capacitance and/or leakage resistances. All the codes of practice known to the author permit

fully-floating intrinsically safe circuits and hence this hazard is largely ignored.

Fortunately the majority of 'fully isolated' circuits such as fire detection circuits are connected to ground via a high value resistor connected for earth leakage detection purposes. Quite a high value of resistance (100kΩ) will serve to prevent a circuit being charged in normal circumstances. The reference potential in these circumstances should be chosen so as not to be subject to high voltage invasion.

The use of earth leakage detection for anticipating field wiring faults, and also for monitoring the performance of circuits where high operational reliability is very important, is a well established technique.

### 18 Intermediate supplies

Usually there are some questions as to whether the supplies connected to the safe-area terminals of interfaces should be earthed or not. In almost all circumstances earthing or bonding one side of a power supply is advisable since it defines a path for capacitive interference currents and makes the analysis of what happens under fault conditions much easier. With all floating systems, the analysis of possible sneak paths caused by multiple earthing is an almost impossible task.

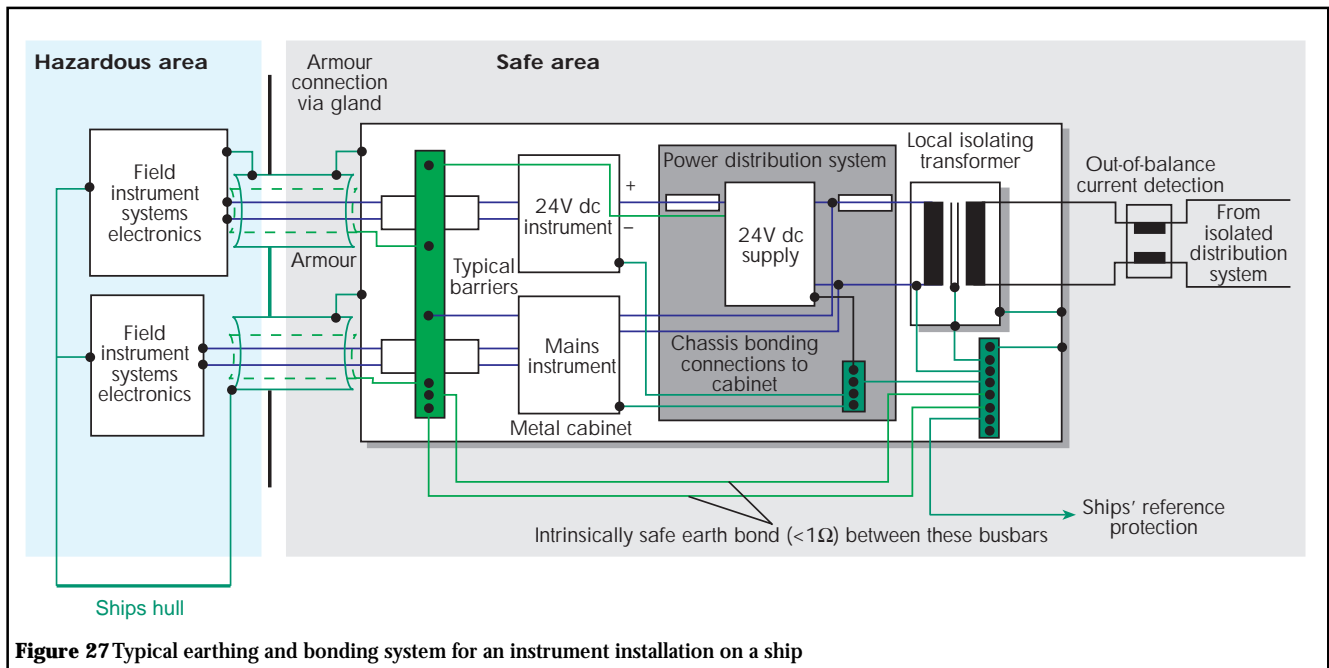
Battery supplies form one of the more common sources of intermediate power, usually as trickle

charged back-up for mains supply failure. Overheating and emission of oxygen and hydrogen create significant problems and if possible it is advisable to avoid locating batteries in a hazardous area. The need for adequate ventilation and good installation and maintenance requires attention in any type of installation, so as to avoid the hazards associated with standby batteries. Floating batteries, particularly where the battery output is taken to several circuits via extensive field wiring, usually create numerous sneak path possibilities and hence are best avoided. If floating battery systems must be used then the use of shunt diode safety barriers is possible but very difficult. The use of isolators with three-port isolation is the preferred option.

### 19. Ships

In general the primary source of power in ships is generated as a floating system with earth leakage monitoring in order to give maximum availability of the critical systems under fault and emergency conditions. However, from an explosion safety viewpoint the hull of the ship is the reference potential and the safety requirement is met by preventing significant voltage differences between the hull and the intrinsically safe circuits.

The usual solution is as illustrated in figure 27 where a mains power supply (usually 110V) is developed from the floating supply and referenced to the hull. The installation can then utilise the code of practice relating to land based installations.



**Figure 27** Typical earthing and bonding system for an instrument installation on a ship

TP1117, whimsically entitled 'Undercurrents in Marine IS Earthing', is nevertheless a more comprehensive account of the use of intrinsically safe equipment on ships.

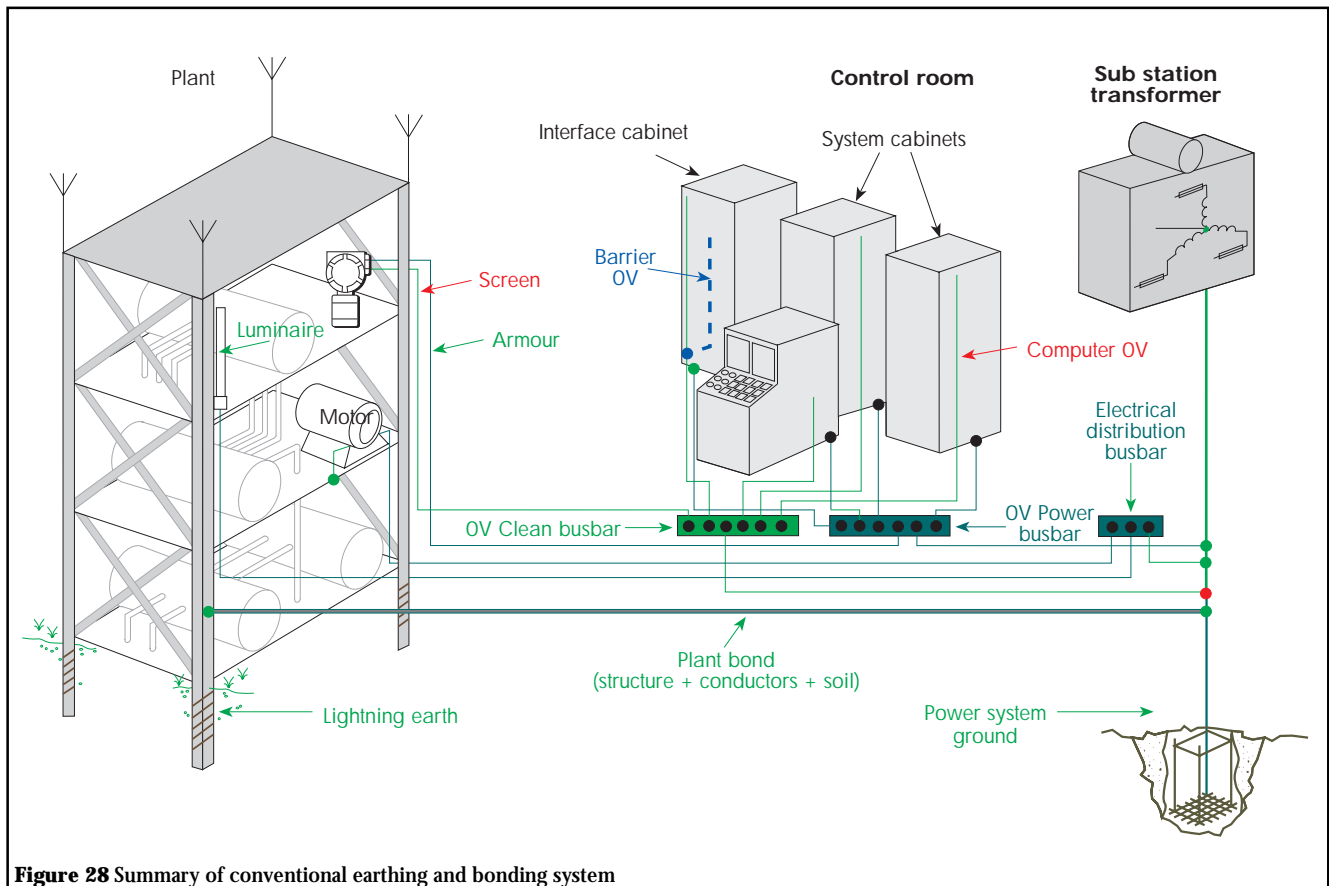
## 20 Offshore installations

Where the generation of power is on the offshore installation then the possible power fault paths are well defined. Usually multiple generators feed into a distribution system which feeds a 440V 3-phase transformer which has its neutral star point referred to the rig at one point. This point becomes the reference point

of the rig and the installation can proceed using the same code of practice as an onshore installation.

In practice, on steel-structured installations the impedance of the rig is so low that sensitive earth connections can be made at almost any point. On some installations there are significant magnetic fields and circulating currents in the immediate vicinity of the electrical generation equipment. Apart from this area there are very few problems. There are numerous tales of large circulating currents, significant voltages between deck plates and high radio frequency

fields, but they are always observed by someone else on some other installation and probably do not exist. The problems associated with satellite platforms and sub-sea installations are similar to those considered in section 15.



**Figure 28** Summary of conventional earthing and bonding system

## 21 Conclusion

Whenever the earthing and bonding plan of an installation is complete the following checklist should be followed:

- 1 Are all electrically conducting objects bonded together?
- 2 Have return paths for all fault currents been provided? Are they secure and robust?
- 3 Is there a significant risk of an adjacent lightning strike?  
Are adequate earth mats provided?  
Are all the earth mats cross-bonded to each other?  
Is the sensitive electronic apparatus protected against surges on both the instrument and power leads?  
In particular are all power and signal leads from distant sources protected?
- 4 Have all the sensitive 0V connections, together with intrinsic safety and surge suppression earths, been collected together at one point?  
Is there a single connection between that point and the plant bond at a point which is normally electrically quiet but will carry the surge current?  
Does the flow of these fault or surge currents generate an acceptable voltage difference in the hazardous area?

5 Is there an electrostatic problem and have the necessary precautions been taken?

6 Is there a Zone 0 and has special care appropriate to this most hazardous area been taken?

A positive response to these prompts increases the probability of the plant being safe and operationally reliable.

Having done all these things, get someone else to check it.

Figure 28 illustrates the best solution for conventional industrial locations and is the answer to almost all problems. The more complex situations are relatively unusual.

Appendix 1 deals with the possible connections of screens in almost all foreseeable circumstances. It is an interpretation of the British Standard Code of Practice by the author but it has existed for some time and has been widely discussed and agreed in various appropriate committees. It can therefore be regarded as having considerable status.

Figures 1 to 6 illustrate various possible combinations of screens within cables, figure 7 illustrates the usual installation of an armoured cable with both internal and overall screens.

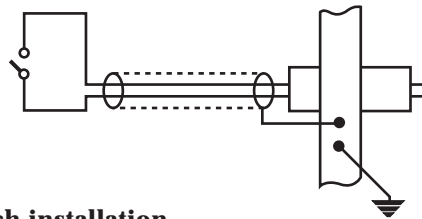
### Appendix 1

The following examples illustrate the more common combinations of 'earthed' circuits and screens.

#### Example 1

Requirements for screens in intrinsically safe cables.

Cable construction



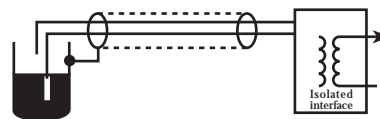
**Figure 1: Conventional limit switch installation**

The screen is shown connected to the barrier 0 volt rail. This illustrates the usual circumstances for individual circuits. It is not however essential for safety reasons; the screen could be bonded at the switch and isolated at the barrier if this is considered operationally desirable.

*Note: Although failure between the wires and between the wire and screen does not create an incendive spark, it is usual for cables to conform to the insulation requirements. This does not preclude the possibility of using bare wires and/or bare screens in exceptional circumstances.*

#### Example 2

Cable construction



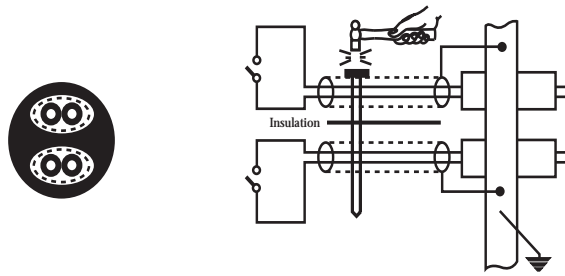
**Figure 2: Conventional level switch installation**

The cable construction is identical to that of the previous application.

The screen is shown bonded to the liquid container and isolated at the interface, which would be the usual circumstances. However, it is permitted to bond the screen at the interface and isolate it at the container.

### Example 3

Cable construction



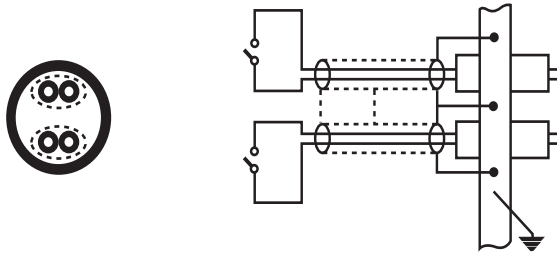
**Figure 3: Limit switches in common multicore possibly subject to mechanical damage**

In this installation the two screens are necessary to prevent an accidental interconnection between the two circuits. The integrity of each screen can be readily established if the screens are insulated from each other.

The two screens should be independently connected to the 0V rail as indicated.

### Example 4

Cable construction



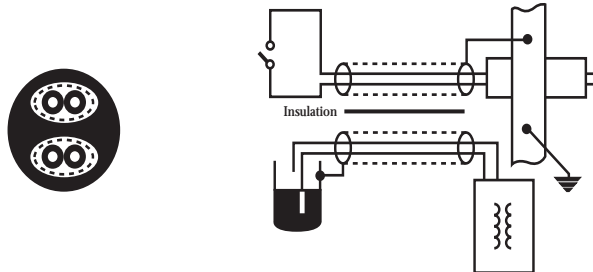
**Figure 4: Limit switches connected via a multicore adequately supported and protected.**

Where the screens are not required for safety purposes, and provided that they are all bonded at the same place, there is no requirement for insulation between the screens. They must however be insulated from the circuit cores and have an overall cover to prevent inadvertent contact with earthy cable trays, etc.

This does permit the use of multicores made up from separately screened quads etc, commonly used for vibration transducers and similar devices.

### Example 5

Cable construction

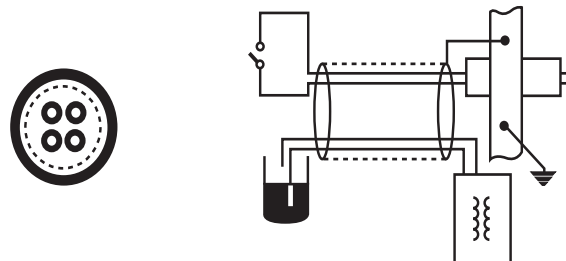


**Figure 5: Limit switch and float switch in individually screened circuits bonded at different points**

If the two circuits of figure 1 and figure 2 are combined into one multicore, then the two screens are bonded at different points and hence must be isolated from one another. It may be more practical to bond both screens at the barrier 0V rail. Assuming the two screens have to be bonded at the points illustrated then the cable construction becomes as illustrated.

### Example 6

Cable construction



**Figure 6: Circuits bonded at different points with an overall screen**

If the two circuits of figure 1 and figure 2 are combined in one multicore with an overall screen, then that screen may be bonded at any point and insulated to withstand a test of 500V elsewhere.